



Unical Aero, Inc. is a U.S. based design, engineering and manufacturing company of non-OEM, FAA-approved aircraft parts and components for commercial and military applications. Our customers include domestic and international airlines, MROs, governments and aviation operators looking for high quality parts. Unical Aero is uniquely positioned to provide customers with cost-effective solutions at scale. [unicalaero.com](http://unicalaero.com)

# H2561-17-135UA

## Latch Assembly

OEM Hartwell #: H2561-17-135



**Installs on:**  
**Fuselage Doors**

**B737-600, 700, 800, 900 SERIES**  
**B777-200, 300 SERIES**

Unical Aero H2561-17-135UA Latch Assembly is installed on various fuselage doors to hold the door in place. The Latch Assembly consists of 5 primary components for functionalities and assembly. The Button Bracket is a casting unit that serves as a rigidity base for installation and components mounting. The Connector joins the Button Bracket with the rest of the assemblies. The actuation of open-closed function is with the Button assist by the Bolt and Springs. The sets-Screw at the end of the Bolt is the primary transfer of force component to secure the Door.

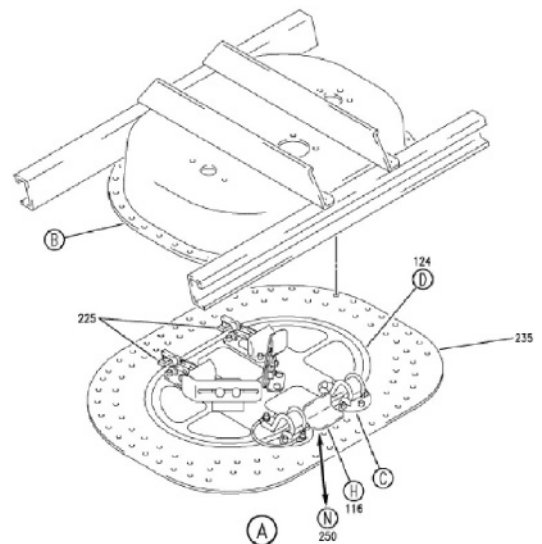

**Unical Aviation, Inc. is the exclusive distributor for Unical Aero products. Please contact Unical Aviation for more information:**  
**+1.909.348.1700 • [sales@unical.com](mailto:sales@unical.com)**



**680 South Lemon Avenue • City of Industry, CA 91789 USA**  
**Fax: +1.909.869.7685 • AOG: +1.626.337.2108 • [unical.com](http://unical.com)**